

5.2 NASA update on current and future missions

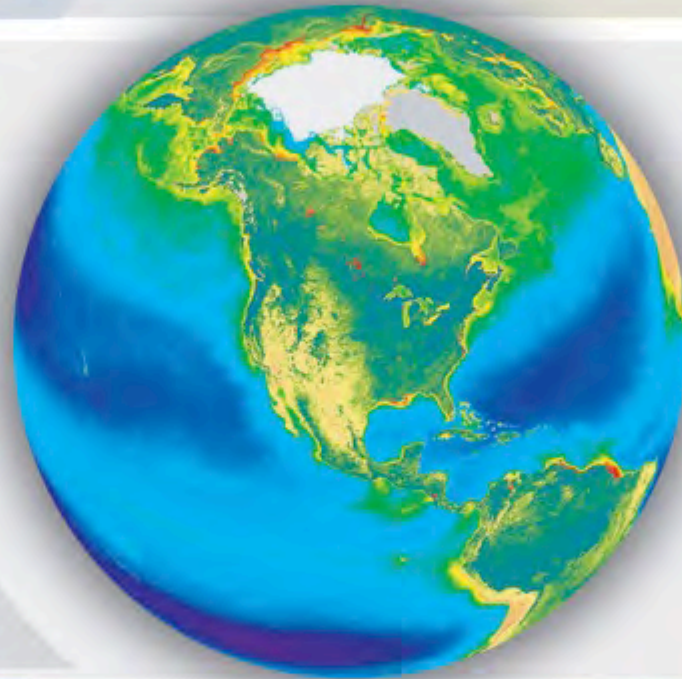

**Paula Bontempi, Bryan Franz, Jeremy Werdell (and the OBPG staff)
NASA Headquarters & NASA GSFC
IOCCG-24 Meeting – Hanoi, Vietnam
4-6 April 2019**



JPSS J1 (NOAA-20) VIIRS data processing

NASA OBPG is processing J1 VIIRS with standard algorithms and producing/distributing continuity ocean color products, but with no vicarious calibration applied, and instrument calibration “as is”.

Results are in reasonable agreement with SNPP VIIRS products, no rigorous validation yet done.

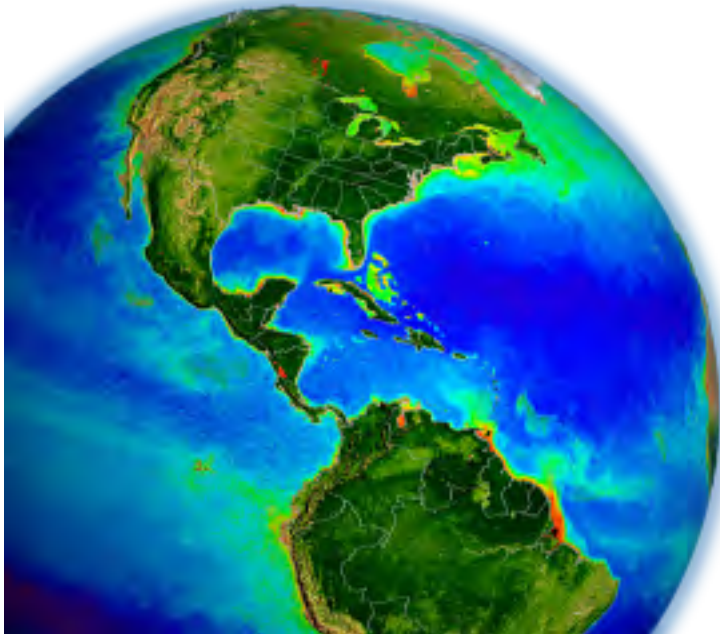

Bryan Franz

and the

Ocean Biology Processing Group
NASA Goddard Space Flight Center



PACE update – IOCCG-24

4-6 April 2019, Hanoi, Vietnam,

Jeremy Werdell, Paula Bontempi

NASA GSFC, NASA HQ

PACE

Plankton, Aerosol, Cloud, ocean Ecosystem

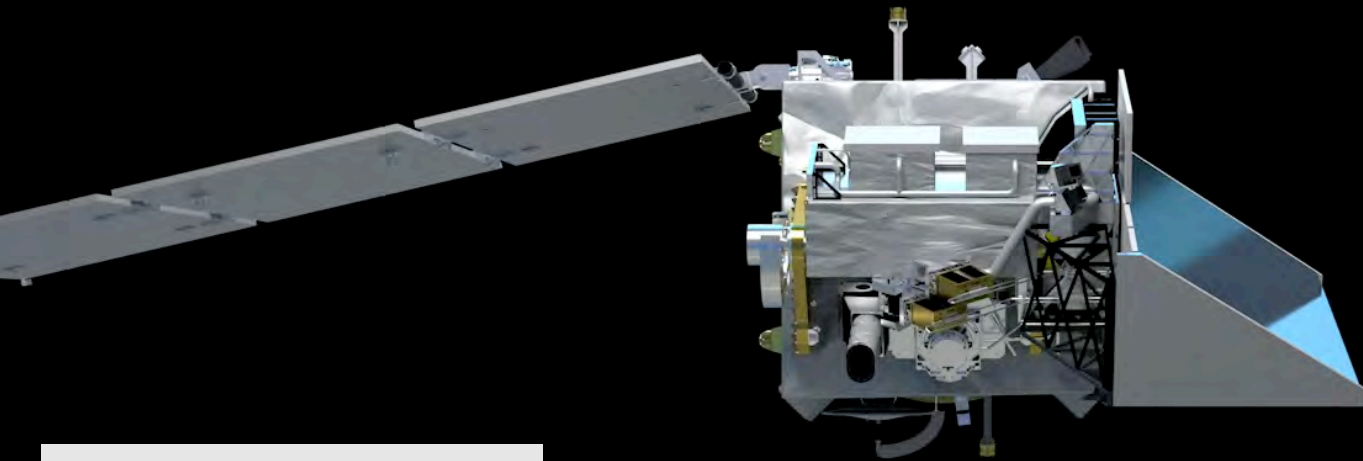

Cost, Schedule, Lifespan

- \$805M Design-to-Cost
- Category 2, Class C
- ~Dec 2022 launch
- 3-year design life
- 10-years of propellant

Orbit

- 675.5 km altitude
- Polar, ascending orbit
- Sun synchronous
- 98° inclination
- 13:00 local Equatorial crossing

- 340 – 890 nm at 5 nm resolution
- Plus, 940, 1038, 1250, 1378, 1615, 2130, and 2250 nm
- 1 – 2 day global coverage
- Ground pixel size of 1 km² at nadir
- ± 20° fore/aft tilt to avoid Sun glint
- Twice monthly lunar calibration
- Daily on-board solar calibration
- Performance that meets or exceeds heritage
- Built at NASA Goddard Space Flight Center

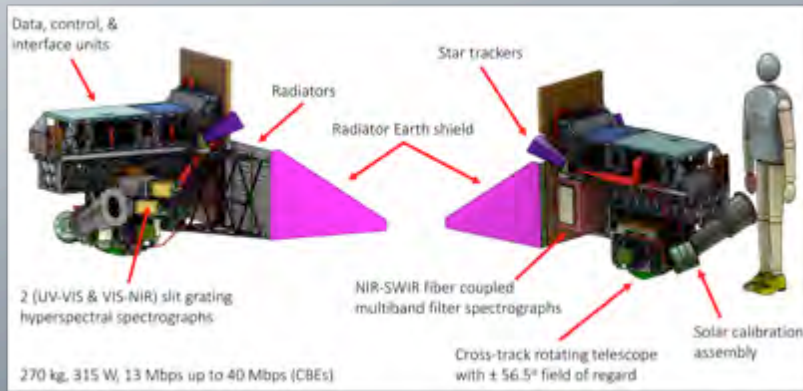

Plankton, Aerosol, Cloud and ocean Ecosystem (PACE) Instruments

(Primary) Ocean Color Instrument (OCI)

Wide swath, UV-VIS imaging spectrometer with SWIR channels designed for ocean color applications, useful for aerosols and clouds

- Preliminary design review (PDR): Mar 2018
- Critical design review (CDR): Dec 2019

Hyper Angular Rainbow Polarimeter 2 (HARP2)

wide-swath multi-angle polarimeter, hyper-angle capability

- PDR: Aug 2018
- CDR: Apr 2019

Spectro-Polarimeter for Planetary Exploration (SPEXone)

narrow-swath hyperspectral, multi-angle polarimetric spectrometer

- PDR: Jul 2018
- CDR: Feb 2019

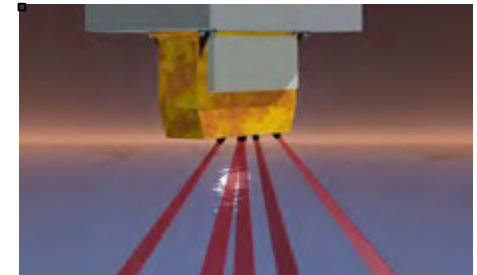
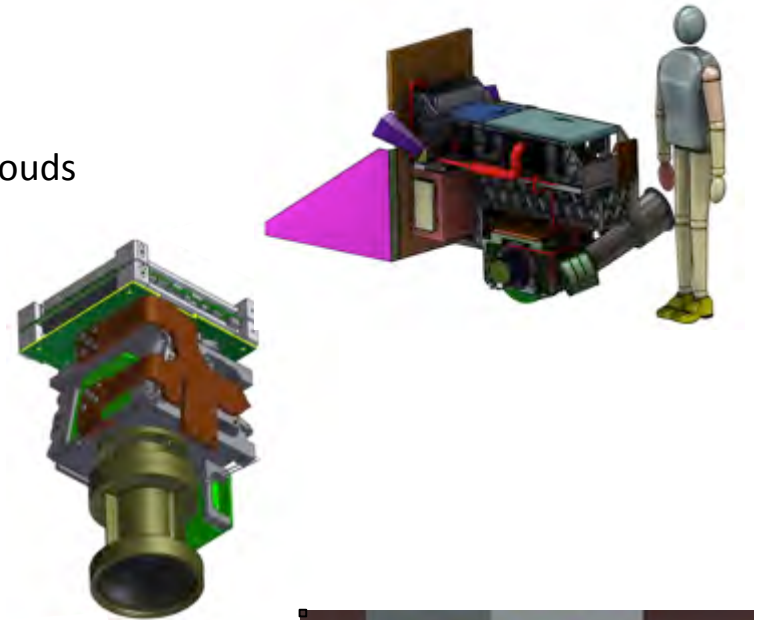

Programmatic update & future science teams

Looking forward: noteworthy mentions

Budget Status: FY20 and beyond (as of early Mar 2019)

- The Budget requests a total of \$21 billion for NASA, \$1.7798 billion for Earth Science
- FY20 President's Budget maintains the Administration's previous termination of two Earth Science missions—PACE and CLARREO Pathfinder—lower priority science. Terminates NASA's Office of STEM Engagement.

2017-2027 Decadal Survey for Earth Science and Applications from Space

- Free download: <http://sites.nationalacademies.org/DEPS/ESAS2017/index.htm>
- Program of Record – “The series of existing or previously planned observations, which should be completed as planned. Execution of the ESAS 2017 recommendation requires that the total cost to NASA of the Program of Record flight missions from FY18-FY27 be capped at \$3.6B.”

Looking Forward: PACE Science Team pre- & post-launch schedule

Pre-launch Science and Applications Teams

- FY15 – 17: ROSES 2013 A.25
 - Pursued consensus and community-endorsed paths forward for IOPs & atmospheric correction
 - Final reports are being submitted and will be compiled into a NASA Technical Memo.
- **FY20 – 22: ROSES 2019 A.38 (3 years)**
 - Allow lead time for pre-launch scientific algorithm & applications development prior to launch
 - Initiates interface between algorithm developers and OBPG/OB.DAAC
- FY23 – 25: ROSES 2022 [TBD] (~3 years)
 - At-launch algorithms and post-launch competed science/applications for OCI's aerosol, cloud, & ocean science, plus aerosol & clouds (& oceans?) from SPEXone & HARP-2

Post-launch competed sciences teams (TBD)

- Most likely competed through ROSES 2025
- To continue during mission extension(s)

Looking forward: vicarious calibration

ROSES 2014 A.3 OBB (FY15-17) - written and competed before PACE was a real mission

- Issued under OBB, managed jointly between OBB and ESTO
- Allowed lead time for concepts to mature prior to launch & Identified technical development needs/risks for the approaches selected
- Three projects funded that have completed analysis and tests of hardware

ROSES 2018 A.49 (amendment 22 Feb 2019)

- Select best approach and hardware for further risk reduction on instrumentation for OCI ocean color vicarious calibration
- Two selections with a down-select after 12 months
- 4 year horizon
- NOIs were due 26 March, proposals 23 May
- Completely open competition (US-based PI's); international collaborators welcome

options: systems in development, expected external assets (BOUSSOLE, MOBY), FRM4SOC (Copernicus/EUM), other *in situ* sources, models

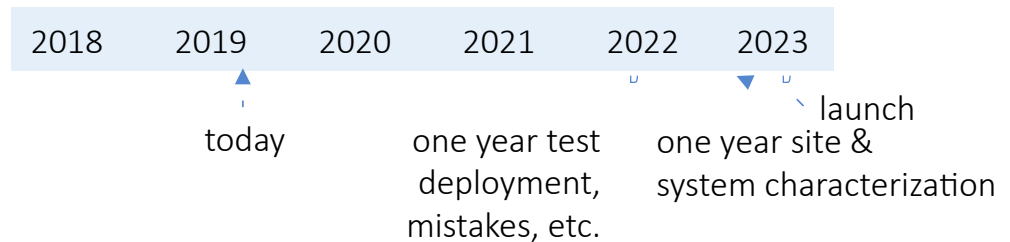

Looking forward: a validation program

FY22 – FY25 (TBD): ROSES 2021 &
 FY26 – FY28 (TBD): ROSES 2025

- Perform validation experiments during mission ops for all data products (aerosol, cloud, ocean color), including validation of polarimetry data products as possible
- Include airborne (as possible) and *in situ* measurements

International community (e.g., ESA, EUMETSAT, and the Copernicus Program) are investing in Fiducial Reference Measurements for Sentinel and **coordination is critical**

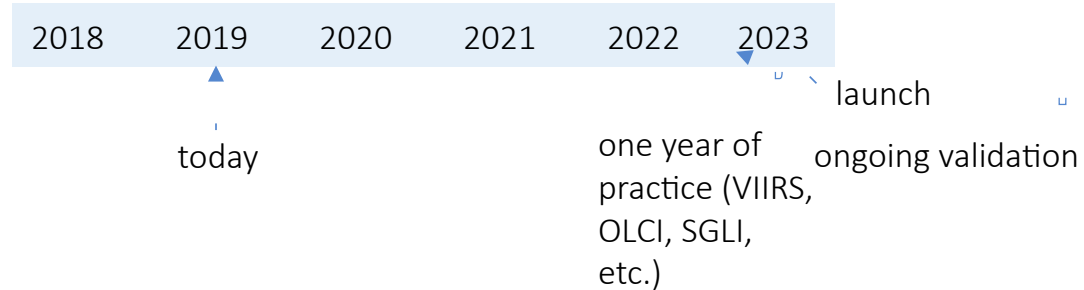

Level 1 required (~threshold) products

Water-leaving reflectance	Aerosol optical thickness
Chlorophyll-a	Aerosol fine mode fraction
Phytoplankton absorption	Liquid / ice cloud optical thickness
NAP+CDOM absorption	Liquid / ice cloud effective radius
Particulate backscattering	Cloud layer detection ($\tau < 0.3$)
Diffuse attenuation	Cloud top pressure ($\tau > 3$)
Fluorescence line height	Shortwave radiation effect

Uncertainty requirements accompany all L1 req'd data products (i.e., we need quantitative validation of all of these products)

Learn more about PACE



PACE

<https://pace.gsfc.nasa.gov>
@NASAOcean (Twitter)
@NASAOcean (Facebook)
Technical Memo. series



PACE Plankton, Aerosol, Cloud, ocean Ecosystem

HOME ABOUT MISSION CONTACT APPLICATIONS CAPSULES NEWS GALLERY

PACE Plankton, Aerosol, Cloud, ocean Ecosystem

NASA Sets the PACE for Advanced Studies of Earth's Ocean and Atmosphere

PACE's advanced remote sensing will provide unprecedented insight into Earth's ocean and atmosphere, which support our prosperity while the ongoing climate and trading our planet's resources. Our oceans team with life, supporting many of Earth's ecosystems. The atmosphere in Earth's living ocean will be measured with PACE's global observations, such as the quantity of organisms, feeding marine food webs and how ecosystems respond to environmental change. PACE will observe our atmosphere to study clouds along with their air-borne particulates as particles, loading in the ocean, clouds, and aerosols together will advance our knowledge of the links each play in our changing climate.

PACE's data will show interactions between the ocean and atmosphere, including how they contribute to global climate and how atmospheric aerosols might fuel phytoplankton growth in the surface ocean. Found uses of PACE data - from identifying the extent and duration of harmful algal blooms to improving our understanding of air quality - will result in direct economic and societal benefits. By measuring and modeling PACE's long record of satellite observations of our living planet, we will take Earth's pulse to have never before recorded in time.

NASA's long-term chlorophyll record is unparalleled



PACE will show all chlorophyll is not created equal

Why Do We Need PACE?

Home | About | Mission | Contact | Applications | Capsules | News | Gallery

Our oceans sustain life and provide us with other resources besides oil or coal or gas. The ocean provides, directly, indirectly, and indirectly, energy and food for many species of life. The health of life in these habitats is dependent on microscopic algae that float in our oceans. Known as "phytoplankton," these tiny organisms come in many different shapes, sizes, and colors. The diversity of phytoplankton has determined the color of the sea for centuries. It also determines how much solar energy flows from the sun and what form that energy takes.

NASA/TM-2018-219027/ Vol. 3



PACE Technical Report Series, Volume 3

Yona Cotner, Charles R. McClain, and P. Jeremy Herdell, Editors

Polarimetry in the PACE Mission: Science Team Consensus Document

PACE Science Team

National Aeronautics and
Space Administration

Goddard Space Flight Center
Greenbelt, Maryland 20771

backup

NASA OBPG Update

Bryan Franz

and the

Ocean Biology Processing Group
NASA Goddard Space Flight Center

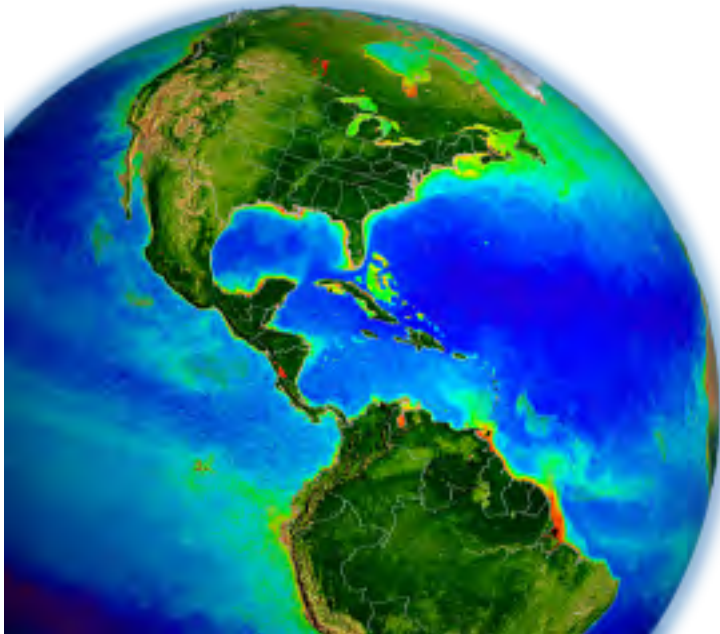

2019 IOCCG Committee Meeting

4-6 April 2019, Hanoi

UMBC Hyper Angular Rainbow Polarimeter (HARP-2)



SRON Spectropolarimeter for Planetary Exploration (SPEXone)

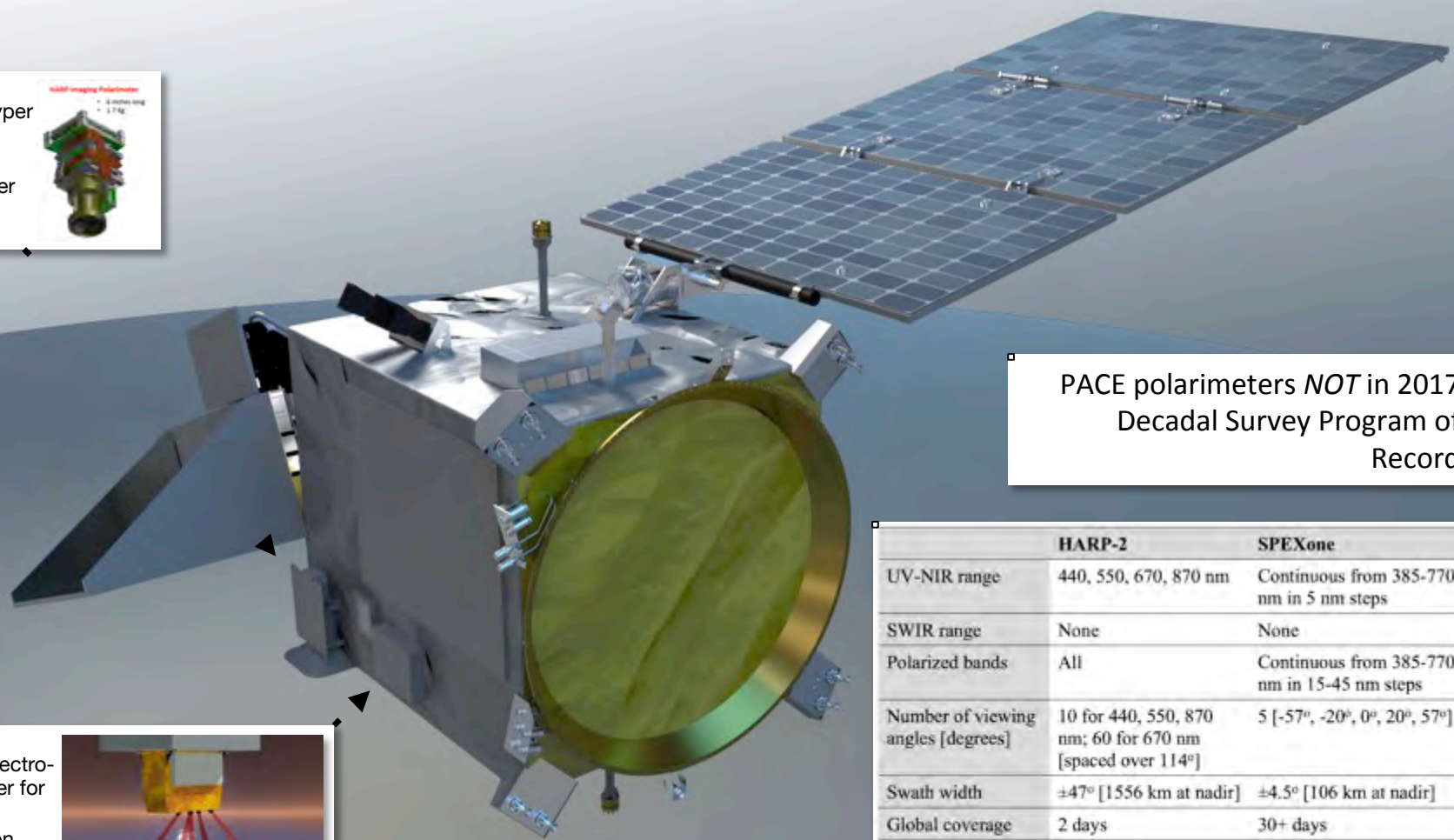

PACE polarimeters *NOT* in 2017 Decadal Survey Program of Record

	HARP-2	SPEXone
UV-NIR range	440, 550, 670, 870 nm	Continuous from 385-770 nm in 5 nm steps
SWIR range	None	None
Polarized bands	All	Continuous from 385-770 nm in 15-45 nm steps
Number of viewing angles [degrees]	10 for 440, 550, 870 nm; 60 for 670 nm [spaced over 114°]	5 [-57°, -20°, 0°, 20°, 57°]
Swath width	±47° [1556 km at nadir]	±4.5° [106 km at nadir]
Global coverage	2 days	30+ days
Ground pixel	3 km	2.5 km
Heritage	AirHARP, Cubesat	AirSPEX

Looking forward: the mission's coming year(s)

Phase B – preliminary design & technology completion (mission PDR in Jun 2019)

Phase C – final design & fabrication (Aug 2019)

- All mission elements must pass Critical Design Reviews (CDR) (~Dec 2019)
- Preceded by series of sub-element Engineering Peer Reviews (EPRs)

- Project & HQ Science + OBPG Science Data Processing:
 - respond to element issues (study, charge/retreat, provide therapy)
 - implement science capabilities (plans for cal, val, algs, processing, documentation, etc.)
 - Interact with newly formed Science Teams

Phase D – system assembly, integration & testing, & launch (~Sep 2021)

Phase E – science operations (~Dec 2022)

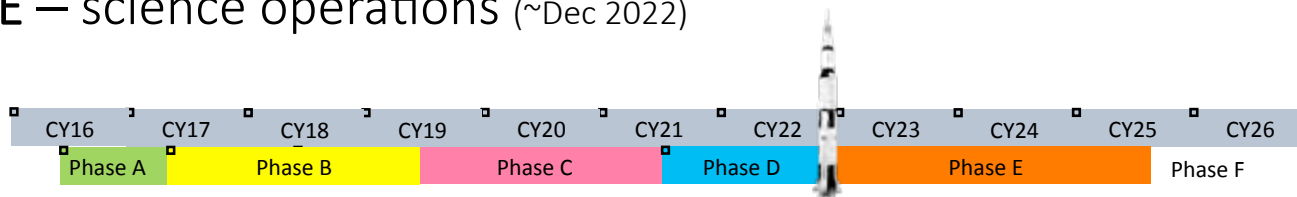

Mission update

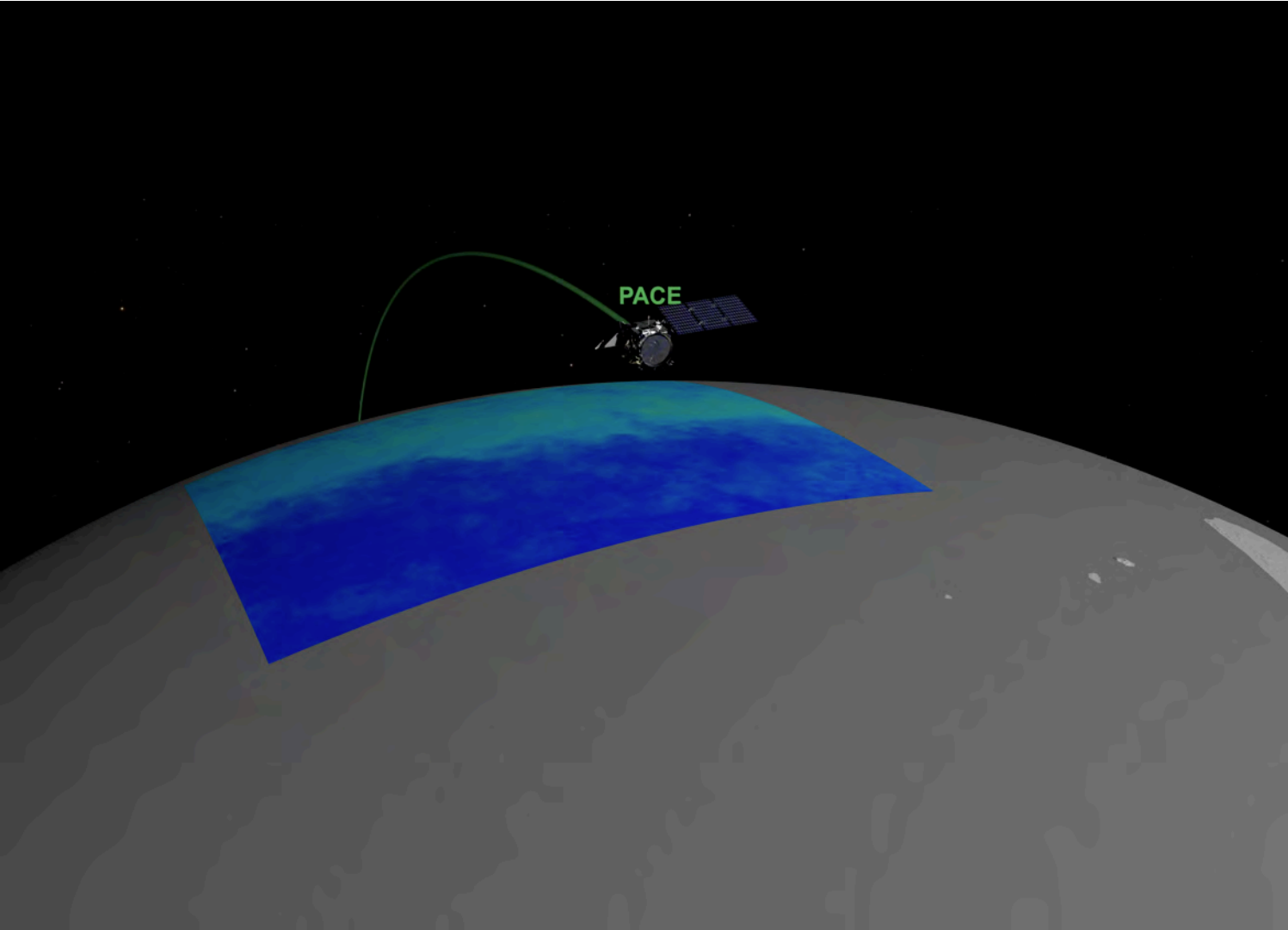

Legacies:

- CZCS
- SeaWiFS
- POLDER
- MODIS
- MISR
- MERIS
- VIIRS
- OLCI
- SGLI
- others

Agenda:

- mission update
- programmatic update, cal/val, & future community opportunities
- instrument updates
- Q&A

PACE will provide insight into systems that affect our everyday lives

With advanced global remote sensing capabilities, PACE will provide a combination of **atmosphere and ocean observation** to benefit society in the areas of water resources, disaster impacts, ecological forecasting, human health, and air quality.

Users at local, state, federal and international agencies as well as the general public will be able to apply data from PACE to make more informed and robust decisions about their activities.



Air Quality and Human Health

Applications Community Building Activities

Mission Applications Plan

Describes the elements of the applications program for the project, its management, and deliverables from all Phases of the mission



Applications Traceability Matrix

developed with input from the user

Application	Requirements	Traceability	Traceability	Traceability	Traceability	Traceability	Traceability	Traceability	Traceability
...

PACE Application Questions & Concepts

What are the key questions and concepts that users should be aware of when developing their applications?

What are the key questions and concepts that users should be aware of when developing their applications?

What are the key questions and concepts that users should be aware of when developing their applications?

PACE Community Survey

PACE (Polarization, Aerosols, Clouds, SeaWiFS) Mission Start Survey

What is your role?

This survey is designed to gather information from the PACE (Polarization, Aerosols, Clouds, SeaWiFS) Mission Start Survey. It is intended to help us understand the needs of our users and to improve our mission. Your input is very important to us. Please take a few minutes to complete this survey. We will use the information you provide to help us better understand the needs of our users and to improve our mission. We will use the information you provide to help us better understand the needs of our users and to improve our mission.

Applications White Papers

Applications White Papers

These white papers provide detailed information about the various applications that are being developed for the PACE mission. They cover a wide range of topics, including air quality, water resources, and ecosystem health. The white papers are available in both PDF and HTML formats. They cover a wide range of topics, including air quality, water resources, and ecosystem health. The white papers are available in both PDF and HTML formats.

PACE applications by development phase

Mission Phase	Applications Activity
Phase A	Assessment of the community of practice. Development of scientific applications from the PACE data using the instruments operated by the Ocean Color and Temperature (OCT) application matrix development. Collection of user community, including experts. Applications of user interest and passed to experts.
Phase B	Applications white papers developed and sent to the experts. Application of user interest and passed to the experts. Applications of user interest and passed to the experts.
Phase C	Applications of user interest and passed to the experts. Applications of user interest and passed to the experts. Applications of user interest and passed to the experts.
Phase D	Applications of user interest and passed to the experts. Applications of user interest and passed to the experts. Applications of user interest and passed to the experts.

PACE Mission Applications - Contact Us:

Maria Tzortziou | Ali Omar | Woody Turner
 maria.a.tzortziou@nasa.gov | ali.h.omar@nasa.gov | woody.turner@nasa.gov
 212-650-5769 | 757-864-5128 | 202-358-1662

<https://pace.gsfc.nasa.gov/>

@NASAOcean

Instrument updates

Ocean Color Instrument – physical assembly

Scanning concept follows SeaWiFS and VIIRS heritage

Data, control, & interface units

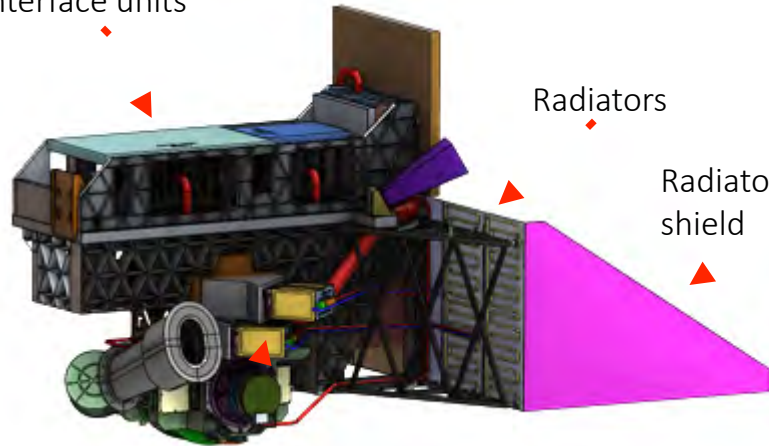

Radiators

Radiator Earth shield

2 (UV-VIS & VIS-NIR) slit grating hyperspectral spectrographs

270 kg, 315 W, 13 Mbps up to 40 Mbps (CBEs)

Star trackers

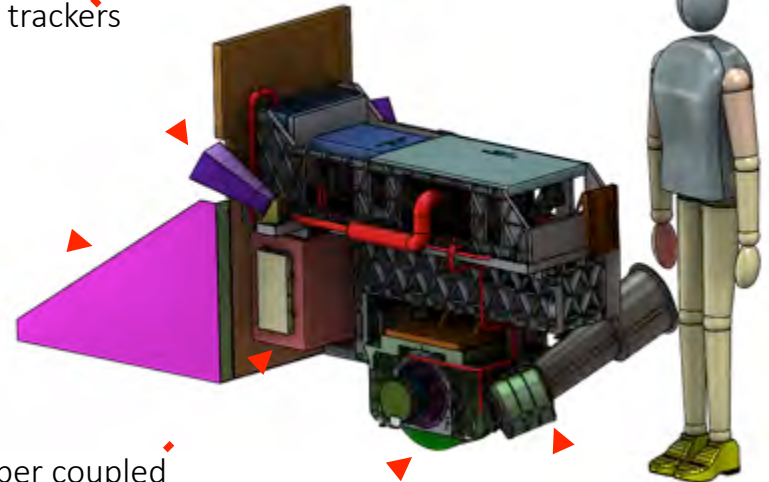

NIR-SWIR fiber coupled multiband filter spectrographs

Cross-track rotating telescope with $\pm 56.5^\circ$ field of regard

Solar calibration assembly

OCI is tilted by $\pm 20^\circ$ to avoid sun glint

SPEXone and HARP-2 are '**contributed**' instruments

Requirements derive from **do no harm** philosophy alone

No requirements for successful data collection or science

Both originally designed as cubesat scale instruments

And, they will provide an excellent proof of concept for atmospheric correction, aerosol, & cloud retrievals

Polarimetry on PACE Two cubesat-sized *contributed* instruments

Spectro-Polarimeter for Planetary Exploration (SPEXone)

Contribution from the Netherlands (SRON, NSO, Airbus; TNO optics)

POC: Otto Hasekamp Hyperspectral (UV) + narrow swath + high accuracy

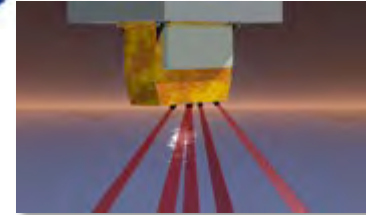

Hyper Angular Rainbow Polarimeter (HARP-2)

Contribution from University of Maryland Baltimore County

POC: Vanderlei Martins Hyperangular + wide swath

	SPEXone	HARP-2
Spectral range (resolution)	385-770 nm (continuous @ 5 nm)	440, 550, 670 nm (10) + 870 nm (40 nm)
Polarized bands	385-770 nm (continuous @ 15-45 nm)	All
Polarimetric accuracy (DoLP)	0.002	< 0.01
# viewing angles	5 (-57°, -20°, 0°, 20°, 57°)	10 for 440, 550, 870 nm + 60 for 670 nm (114°)
Swath width	9° (106 km at nadir); 30+ day global cov.	94° (1556 km at nadir); 2 day global coverage
Ground sample distance	2.5 km ²	3.0 km ²
Heritage	AirSPEX, SPEX/ASPIM	AirHARP, cubesat HARP for ISS

Plankton, Aerosol, Cloud and ocean Ecosystem (PACE) Instruments

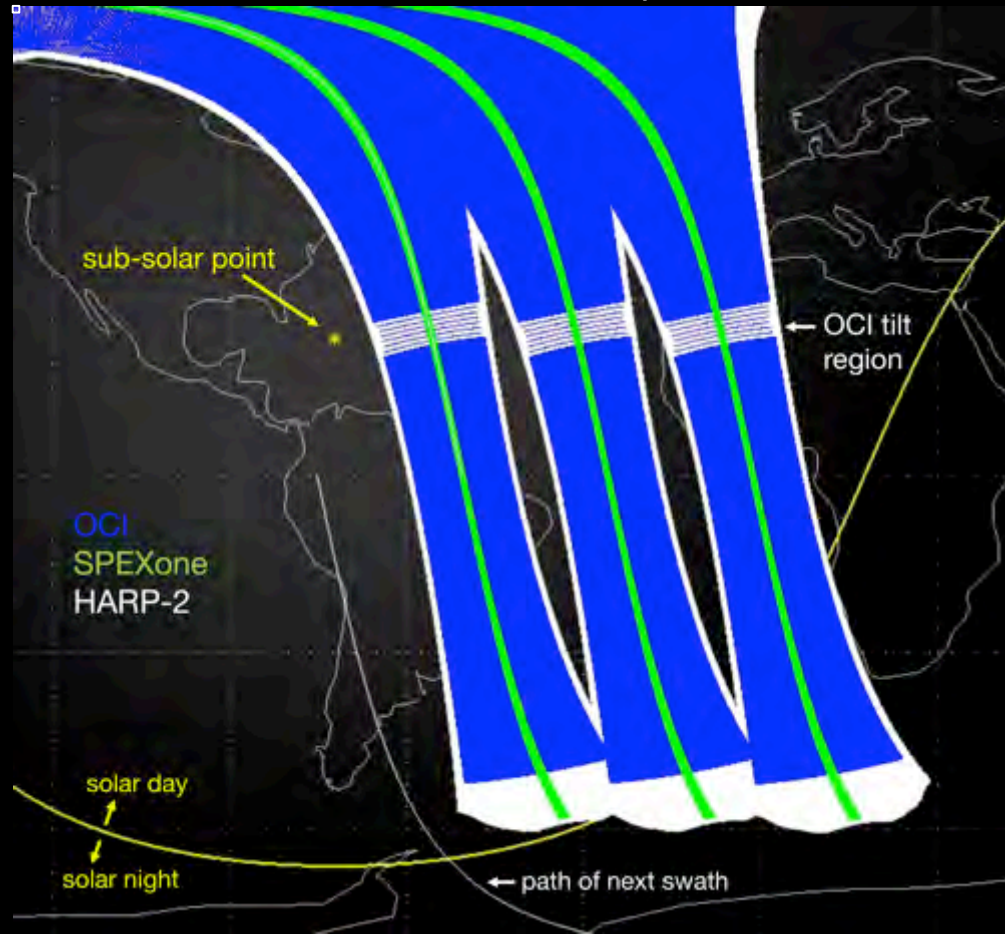

Ocean Color Instrument (OCI) – signal-to-noise (SNR)

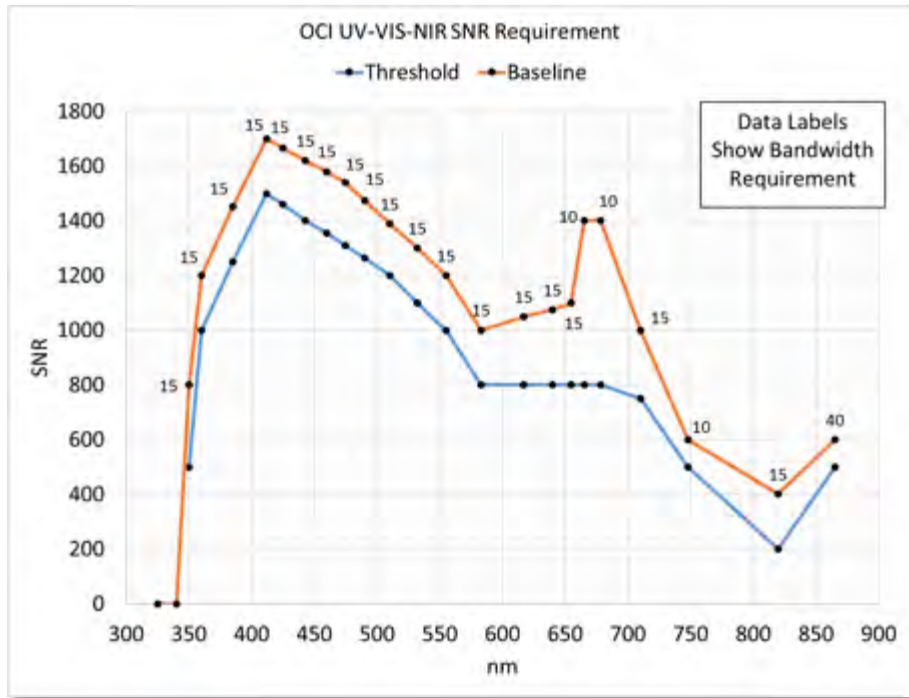

OCI atmospheric improvements over heritage

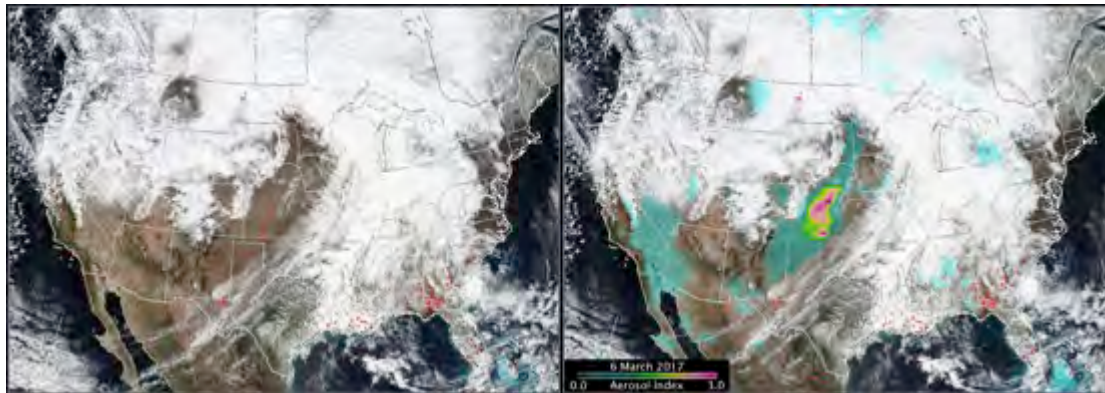

1 km resolution at nadir from UV to SWIR

UV + oxygen-A and B-bands provide opportunities for aerosol algorithms beyond heritage

VIIRS RGB + OMPS Aerosol Index

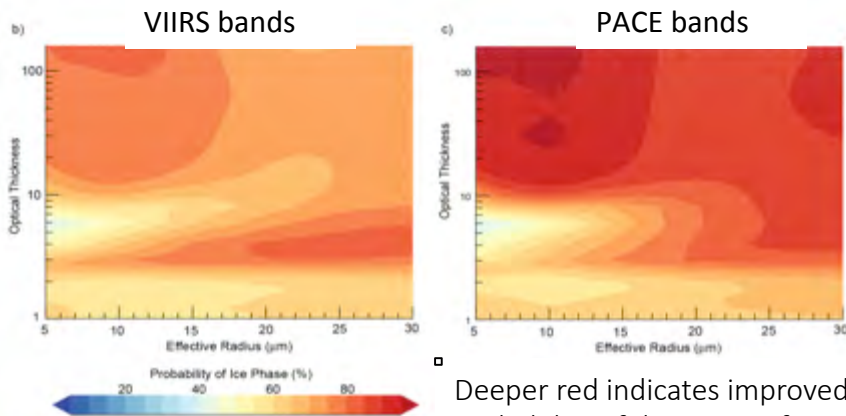

Deeper red indicates improved probability of detection of ice phase

Two 2- μm bands (VIIRS + MODIS) improve retrievals of cloud thermodynamic phase

AGU PUBLICATIONS

Journal of Geophysical Research: Atmospheres

RESEARCH ARTICLE
10.1002/2017JD026493

Characterizing the information content of cloud thermodynamic phase retrievals from the notional PACE OCI shortwave reflectance measurements

O. M. Coddington¹, T. Vukicevic², K. S. Schmidt^{1,3}, and S. Platnick⁴

How will PACE polarimeters perform?

Radiative transfer simulations + information content analysis (Knobelspiesse et al. 2012)

Right – atmospheric correction improvement: ratio of SPEXone/HARP2 water leaving reflectance uncertainty to OCI uncertainty. EUMETSAT 3MI for reference.

Below – aerosol retrieval improvement: degrees of freedom for signal for a simultaneous aerosol & ocean retrieval

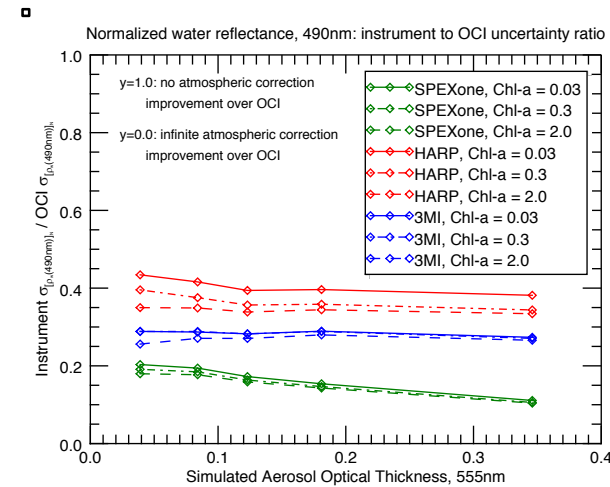

Atmospheric correction improvement

better

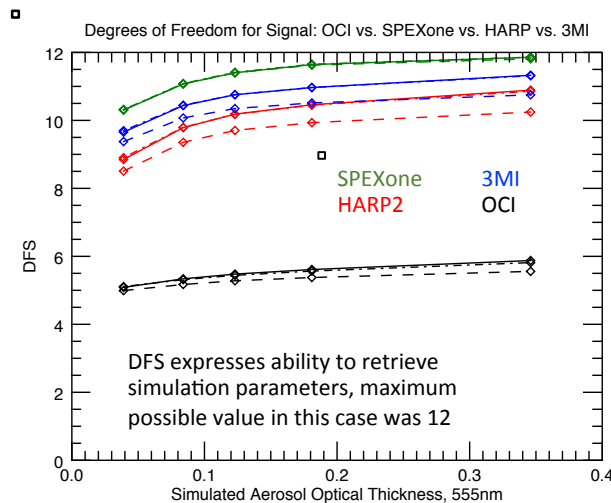

Aerosol retrieval improvement

better



Both offer dramatic improvement, comparable to 3MI

Other characteristics must also be considered, e.g. considerable swath width difference (SPEXone: 9°, HARP2: 94°).

Cloud property retrieval
Hyperangular capability of HARP2 can be used to retrieve droplet size distributions and to characterize ice particle roughness and aspect ratio, which reduces the uncertainty in ice particle size retrievals from OCI.

Operational algorithms must be created to exploit this information.

How will PACE polarimeters perform?

SPEXone:
Example aerosol retrievals from SPEXAirborne during ACEPOL
 Hasekamp et al. AGU 2018

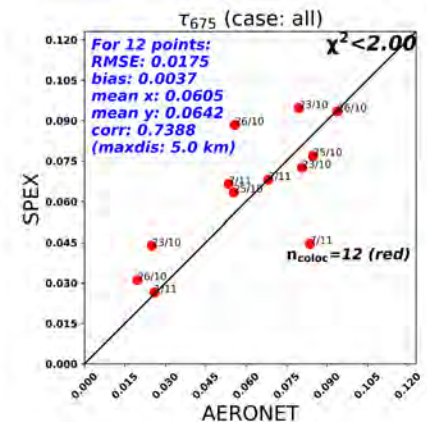
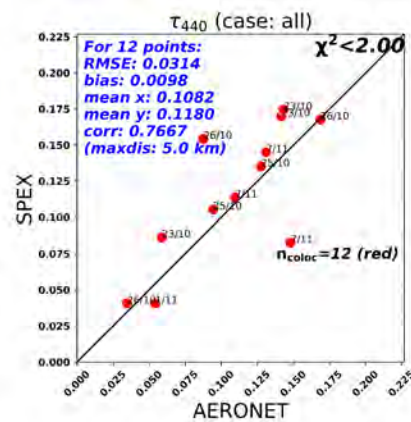
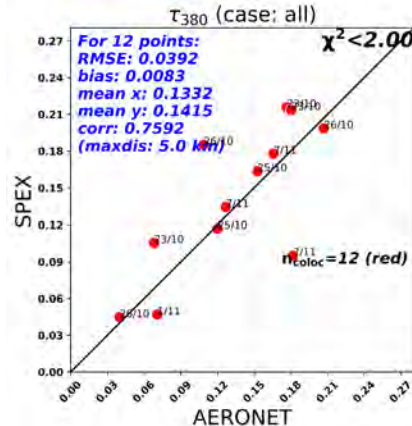

HARP2: Examples of what a hyperangular capability provides

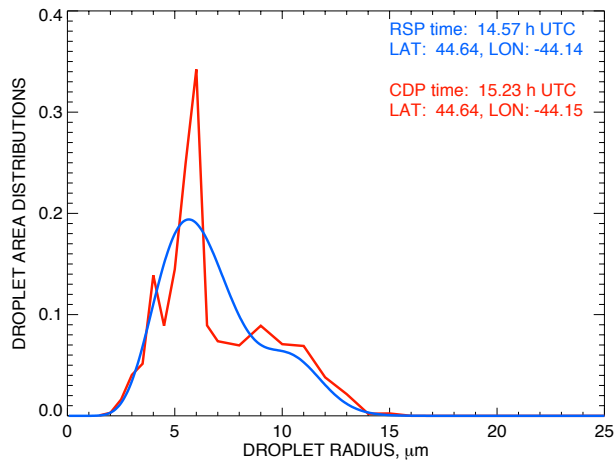

Droplet size distributions

Alexandrov et al. 2018

Wind speeds

Harmel and Chami 2012

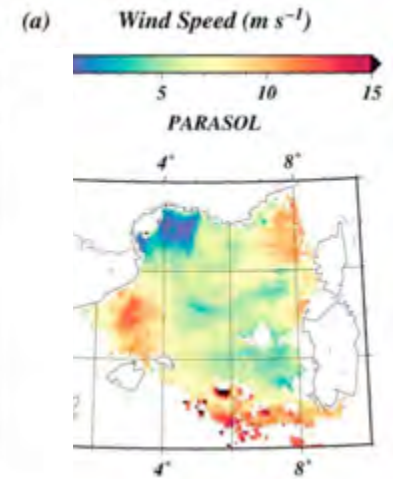
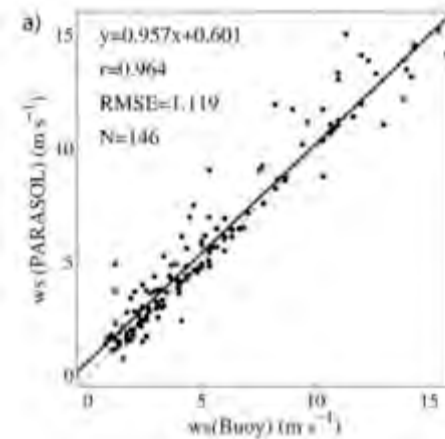

How will PACE polarimeters perform?

SPEXone + HARP2 + OCI: Polarimetric observations compliment OCI ice cloud retrievals

- Polarimetry allows retrieval of ice crystal aspect ratio and crystal distortion, which are fundamental properties determining the scattering asymmetry parameter
- Retrieving asymmetry parameter avoids the need to assume an ice optical model for optical thickness and effective radius retrievals from VIS/SWIR bands

van Dierenhoven et al. (AMT 2012, JGR 2014)

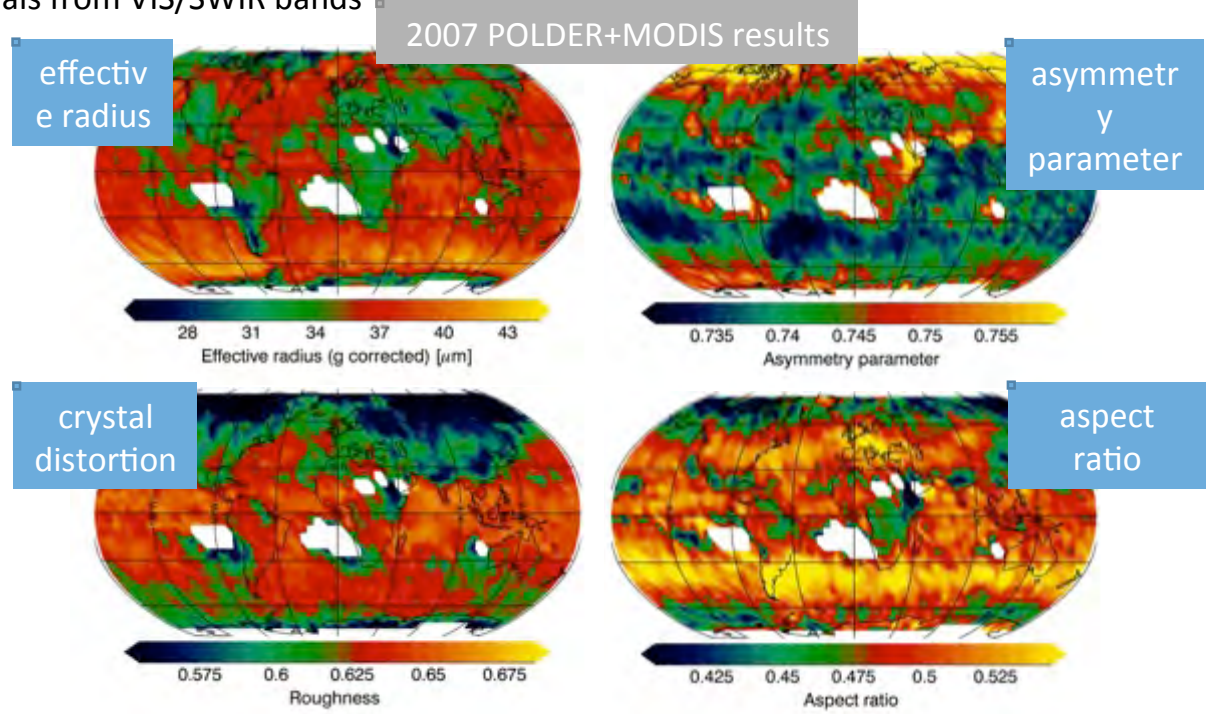
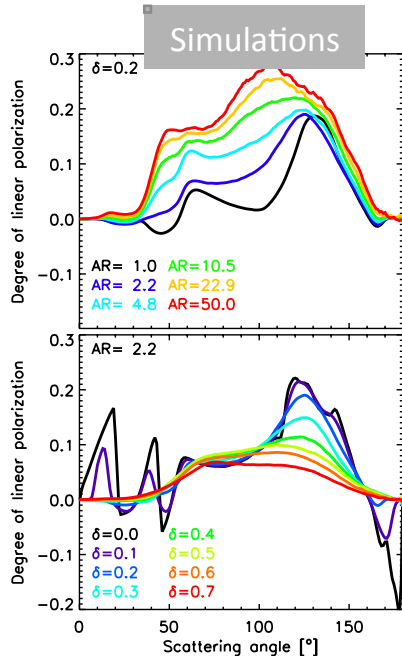

NASA/NOAA/USGS DS 2017 - Recommended NASA Flight Program Elements

- ***Program of Record*** - The series of existing or previously planned observations, which **should be completed as planned**. Execution of the ESAS 2017 recommendation requires that the total cost to NASA of the Program of Record flight missions from FY18-FY27 be capped at \$3.6B.
- ***Designated***. A new program element for ESAS-designated cost-capped medium- and large-sized missions to address ***observables essential to the overall program*** and that are outside the scope of other opportunities in many cases. Can be competed at NASA discretion.
- ***Earth System Explorer***. A new program element involving competitive opportunities for medium-size instruments and missions serving specified ESAS-priority observations. ***Promotes competition among priorities***.
- ***Incubation***. A new program element focused on investment for priority observation opportunities needing advancement prior to cost-effective implementation including an Innovation Fund to respond to emerging needs. ***Investment in innovation for the future***.
- ***Venture***. Earth Venture program element as recommended in ESAS 2007 with the addition of a new Venture-Continuity component to provide ***opportunity for low-cost sustained observations***.

Recommended NASA Priorities: Designated (Table 3.5)

TARGETED OBSERVABLE	SCIENCE/APPLICATIONS SUMMARY	CANDIDATE MEASUREMENT APPROACH	Designated	Explorer	Incubation
Aerosols	Aerosol properties, aerosol vertical profiles, and cloud properties to understand their direct and indirect effects on climate and air quality	Backscatter lidar and multi-channel/multi-angle/polarization imaging radiometer flown together on the same platform	X		
Clouds, Convection, & Precipitation	Coupled cloud-precipitation state and dynamics for monitoring global hydrological cycle and understanding contributing processes	Radar(s), with multi-frequency passive microwave and sub-mm radiometer	X		
Mass Change	Large-scale Earth dynamics measured by the changing mass distribution within and between the Earth's atmosphere, oceans, ground water, and ice sheets	Spacecraft ranging measurement of gravity anomaly	X		
Surface Biology & Geology	Earth surface geology and biology, ground/water temperature, snow reflectivity, active geologic processes, vegetation traits and algal biomass	Hyperspectral imagery in the visible and shortwave infrared, multi- or hyperspectral imagery in the thermal IR	X		
Surface Deformation & Change	Earth surface dynamics from earthquakes and landslides to ice sheets and permafrost	Interferometric Synthetic Aperture Radar (InSAR) with ionospheric correction	X		

Recommended NASA Priorities: Explorer

TARGETED OBSERVABLE	SCIENCE/APPLICATIONS SUMMARY	CANDIDATE MEASUREMENT APPROACH	Designated	Explorer	Incubation
Greenhouse Gases	CO₂ and methane fluxes and trends , global and regional with quantification of point sources and identification of source types	Multispectral short wave IR and thermal IR sounders; or lidar**		X	
Ice Elevation	Global ice characterization including elevation change of land ice to assess sea level contributions and freeboard height of sea ice to assess sea ice/ocean/atmosphere interaction	Lidar**		X	
Ocean Surface Winds & Currents	Coincident high-accuracy currents and vector winds to assess air-sea momentum exchange and to infer upwelling, upper ocean mixing, and sea-ice drift.	Radar scatterometer		X	
Ozone & Trace Gases	Vertical profiles of ozone and trace gases (including water vapor, CO, NO ₂ , methane, and N ₂ O) globally and with high spatial resolution	UV/IR/microwave limb/nadir sounding and UV/IR solar/stellar occultation		X	
Snow Depth & Snow Water Equivalent	Snow depth and snow water equivalent including high spatial resolution in mountain areas	Radar (Ka/Ku band) altimeter; or lidar**		X	
Terrestrial Ecosystem Structure	3D structure of terrestrial ecosystem including forest canopy and above ground biomass and changes in above ground carbon stock from processes such as deforestation & forest degradation	Lidar**		X	

Recommended NASA Priorities: Incubation/Other

TARGETED OBSERVABLE	SCIENCE/APPLICATIONS SUMMARY	CANDIDATE MEASUREMENT APPROACH	Designated	Explorer	Incubation
Atmospheric Winds	3D winds in troposphere/PBL for transport of pollutants/carbon/aerosol and water vapor, wind energy, cloud dynamics and convection, and large-scale circulation	Active sensing (lidar, radar, scatterometer); passive imagery or radiometry-based atmos. motion vectors (AMVs) tracking; or lidar**		X	X
Planetary Boundary Layer	Diurnal 3D PBL thermodynamic properties and 2D PBL structure to understand the impact of PBL processes on weather and AQ through high vertical and temporal profiling of PBL temperature, moisture and heights.	Microwave, hyperspectral IR sounder(s) (e.g., in geo or small sat constellation), GPS radio occultation for diurnal PBL temperature and humidity and heights; water vapor profiling DIAL lidar; and lidar** for PBL height			X
Surface Topography & Vegetation	High-resolution global topography including bare surface land topography ice topography, vegetation structure, and shallow water bathymetry	Radar; or lidar**			X

** Could potentially be addressed by a multi-function lidar designed to address two or more of the Targeted Observables

Other ESAS 2017 Targeted Observables, not Allocated to a Flight Program Element

Aquatic Biogeochemistry

Radiance Intercalibration

Magnetic Field Changes

Sea Surface Salinity

Ocean Ecosystem Structure

Soil Moisture



Field Campaign Planning/Field Project Updates

- **EXport Processes in the Ocean from Remote Sensing (EXPORTS) – Data Mining and OSSEs (2015-2018) Field Campaign (2017-2020)**
 - <http://oceanexports.org>
 - **US NSF is key domestic partner**
 - **Galway Statement and the Atlantic Ocean Research Alliance**
 - **Line P program**
 - **Dave Siegel (UCSB) is the Science Team Leader, Ivona Cetinić (NASA GSFC) is the NASA Project Scientist**
 - **11 NASA teams funded, six NSF teams funded (more may be added)**
 - **International participation welcome**
- **EXPORTS Program Goal: to develop a predictive understanding of the export and fate of global ocean primary production and its implications for the Earth's carbon cycle in present and future climates (link to satellite observations)**
- **NASA Open competition for the program made selections in July 2017, completed field season in the NE Pacific 6 August – 13/14 September (one process and one survey ship)**
 - **Second field season (North Atlantic) is TBD, pending budget, would be spring 2020**
- **All data will be publicly available in SeaBASS**



NASA Ocean Biology and Biogeochemistry Program





NASA OB&B Research – Research Opportunities in Space and Earth Sciences



- **Competitions in 2018-2019 (<https://nspires.nasaprs.com/>):**
 - **The Science of Terra, Aqua, and Suomi National Polar-orbiting Partnership (NPP) Science Team (67/230 proposals selected January 2018)**
 - Terra and Aqua Data include: MODIS (T, A), ASTER (T), MOPITT (T), MISR (T), CERES (T, A), AIRS/AMSU-A (A), AMSR-E (A), and EOS Direct Broadcast sites
 - Suomi NPP - ATMS, VIIRS, CrIS, OMPS, CERES
 - Science Data Analysis + Multiplatform and sensor data fusion
 - Algorithms – New Data Products
 - Real- or Near-Real-Time Data Algorithms
 - NASA Suomi NPP Science Team Leader & Terra, Aqua, Suomi NPP Discipline Leads
 - MODIS-VIIRS Science Team Meeting in the US - October 2018
- **Competitions in ROSES 2018-2019 (<https://nspires.nasaprs.com/>):**
 - **PACE System Vicarious Calibration – ROSES 2018 A.x amendment (22 Feb 2019) [proposals due]**
 - **PACE Science Team – ROSES 2019 A.x [proposals due]**





NASA OB&B Research – Research Opportunities in Space and Earth Sciences



- Competitions in 2018-2019 (<https://nspires.nasaprs.com/>):
 - Carbon Monitoring System – **ROSES 2019 A.x** [proposals due]
 - **Interdisciplinary Science – five topics – ROSES 2019 A.X** [proposals due]
 - Volcanoes in the Earth System
 - Interactions Between Sea Ice and the Atmosphere
 - Polar Ocean/Biology/Biogeochemical Coupling
 - The Life Cycle of Snow
 - Impacts of urbanization on local and regional hydrometeorology
 - Space Archaeology: Using the Past to Inform the Present and Future
 - Exploring the Microbial Biodiversity of the Atmosphere.
- Competitions anticipated in 2020 (<https://nspires.nasaprs.com/>):
 - **Ocean Biology and Biogeochemistry**
 - OBB open
 - EXPORTS synthesis (maybe 2021 to allow for cruise synthesis)
 - **Carbon Cycle Science – anticipated 2020**

